

## Carbon Steel Ice Makers

North Star **Carbon Steel** ice makers are the best choice for non-food related applications requiring large ice making capacities such as concrete cooling, chemical manufacturing, snowmaking, and other recreational uses. The solid carbon steel freezing surface has a high heat transfer rate which allows it to use less energy to produce more ice than other types of freezing surfaces. It also will not chip, flake or pit and is corrosion-resistant while kept below freezing, or with minimal care. Built for industrial use with high quality heavy-duty parts, the North Star **Carbon Steel** ice maker is known for its reliability, durability and simple installation and operation.

### **CARBON Steel Model** **Stainless Steel Components**

- Top Center Gear Housing Cover
- Water Inlet Splash Tube
- Top Ice Plow
- Ice Removal Tools
- Bottom Ice Plow
- Vertical Ice Deflector
- Drip Shield Spray Tube
- Drip Shield
- Water Tank
- Salt Tank
- Water Pump Motor (TENV)

### **Models Available**

- Model 40 Flooded or Forced Recirculation
- Model 60 Flooded or Forced Recirculation
- Model 90 Flooded or Forced Recirculation

### **Standard Equipment**

- Accumulator (not applicable for FC)
- Installation / Service Manual
- Belt Guard
- Drive Unit, Complete
- Emergency Stop Switch
- Gauge Shut-Off Valve
- Inspection Hatch Guard
- Jog Switch
- Load-Limit Device
- Low Pressure Gauge
- Oil Drain Valve
- Pressure Relief Valve
- Refrigerant Liquid Control
- Salt Feeder Device
- Water Float Valve
- Water Flow Control Valve
- Water Make-Up Tank
- Water Pump, Complete

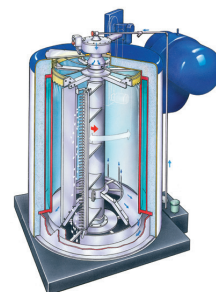

# Carbon Steel Freezing Surface Ice Makers

## Features

- LIFETIME WARRANTY on evaporator. (See full details on warranty sheet)
- U.S.D.A. approved materials.
- Three year warranty on North Star manufactured parts.
- Constructed to ASME code for 250 psig (17.2 Bar) working pressure.
- High R-Value polyurethane insulation.
- Completely protected with reinforced fiberglass exterior.
- Fresh water ice with field adjustable ice thickness.
- Available as Flooded System with Accumulator or Forced Recirculation System without Accumulator

## Other Options Available - Priced on Request

1. UL Electrical control panel (fiberglass enclosure) optional on all CS Models (40 thru 90).

## Notes

1. All ice makers are designed to operate as part of a complete refrigeration system that includes refrigerant, condenser, compressor, and piping **to be supplied by others**
2. Machines shipped on skids, export-crated or containerized
3. Specifications subject to change without notice.

## COMPONENTS

1. Evaporator Freezing Surface inside Drum is solid Carbon Steel
2. Evaporator Bottom Closure Plate is carbon steel.
5. Rotor Top Stem is SS304 steel on Model 40 ice maker, and carbon steel on Model 60 & Model 90

## STAINLESS STEEL COMPONENTS

3. Top Center Gear Housing Cover
4. Water Inlet Splash Tube
6. Top Ice Plow
7. Ice Removal Tools
8. Bottom Ice Plow
9. Vertical Ice Deflector
10. Drip Shield Spray Tube
11. Drip Shield
12. Water Tank
13. Salt Tank
14. Water Pump Motor (TENV)

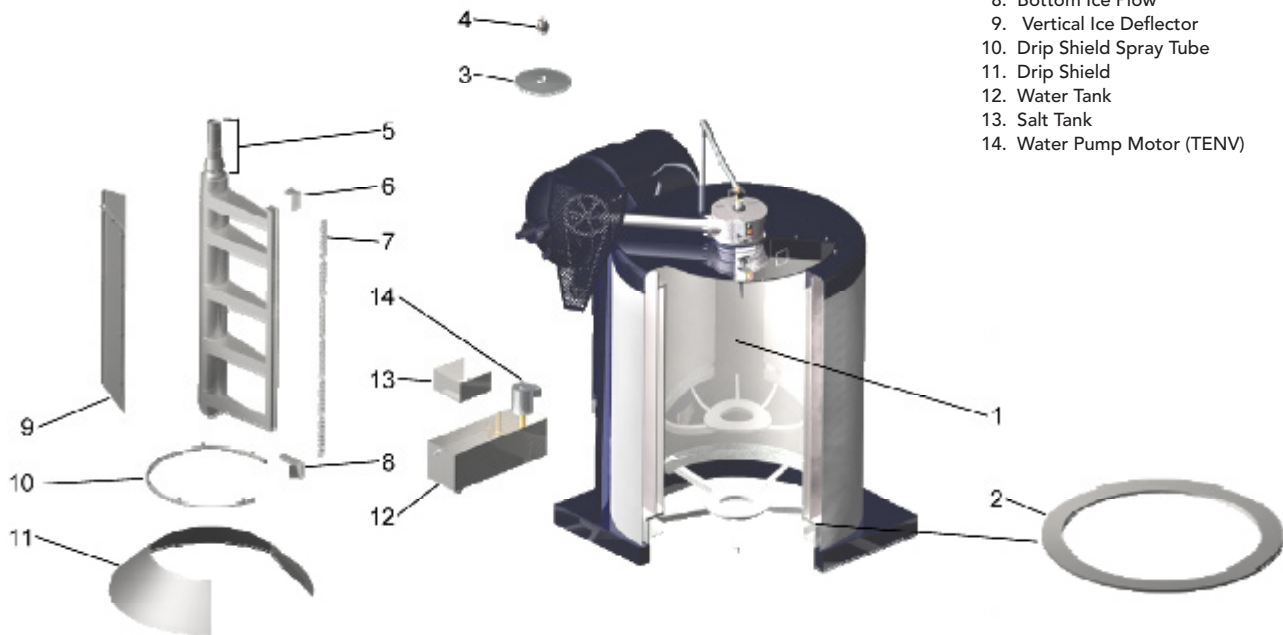

## North Star Ice Equipment Corporation

8151 Occidental Avenue South  
P.O. Box 80227  
Seattle, WA 98108 USA  
Tel: 206-763-7300

Toll-free in USA: 1-800-321-1381  
Fax: 206-763-7323  
Email: [info@northstarice.com](mailto:info@northstarice.com)

*North Star*

[www.northstarice.com](http://www.northstarice.com)