

Case Ice Dispenser

The North Star **Case Ice Dispenser** is a live-bottom short-term storage bin designed for holding up to 1 US ton (0.9 Metric Ton) of flake ice. It can be used in any application that requires dispensing small quantities of ice repeatedly. Its most common use has been in the produce and poultry industries. For example, in the produce industry, ice is dispensed in small quantities into cases and cartons moving on a conveyor. The rate of discharge is up to 7 US tons per hour with the feed hopper being automatically filled from the main delivery system. Standard construction is an insulated aluminum frame, and galvanized agitators and screw conveyor. Also available with all stainless steel components. Plastic hopper standard on either model.

Feature	Benefit
<i>Designed & Manufactured for Reliability & Durability</i>	<ul style="list-style-type: none"> • Robust design • Manufactured with industrial grade components. • Insulated aluminum frame with Starboard ®XL plastic hopper. (Starboard ®XL plastic manufactured entirely with FDA approved materials).
<i>Automatic Shutoff & Refill Cycles</i>	<ul style="list-style-type: none"> • Hopper is refilled at timed intervals. Paddle-type high-level control stops ice delivery from main delivery system when Case Ice Dispenser is full.
<i>Saves Money & Time</i>	<ul style="list-style-type: none"> • Prevents damage to main delivery system which is not designed for short on/off sequences that are repetitively required. • Reduces dispensing time by having ice always available at required area.
<i>Easy to Install</i>	<ul style="list-style-type: none"> • Shipped fully assembled with installation instructions.



Case Ice Dispenser

Major System Components

Frame Assembly
 Hopper Assembly
 Standard CEMA Screw Conveyor Flanged Outlet
 Trough Support Channels

9" Diameter Heavy-Duty Discharge Screw Conveyor
 Agitator Conveyors
 Level Control Assembly (120 or 220 V)
 Plastic Hopper

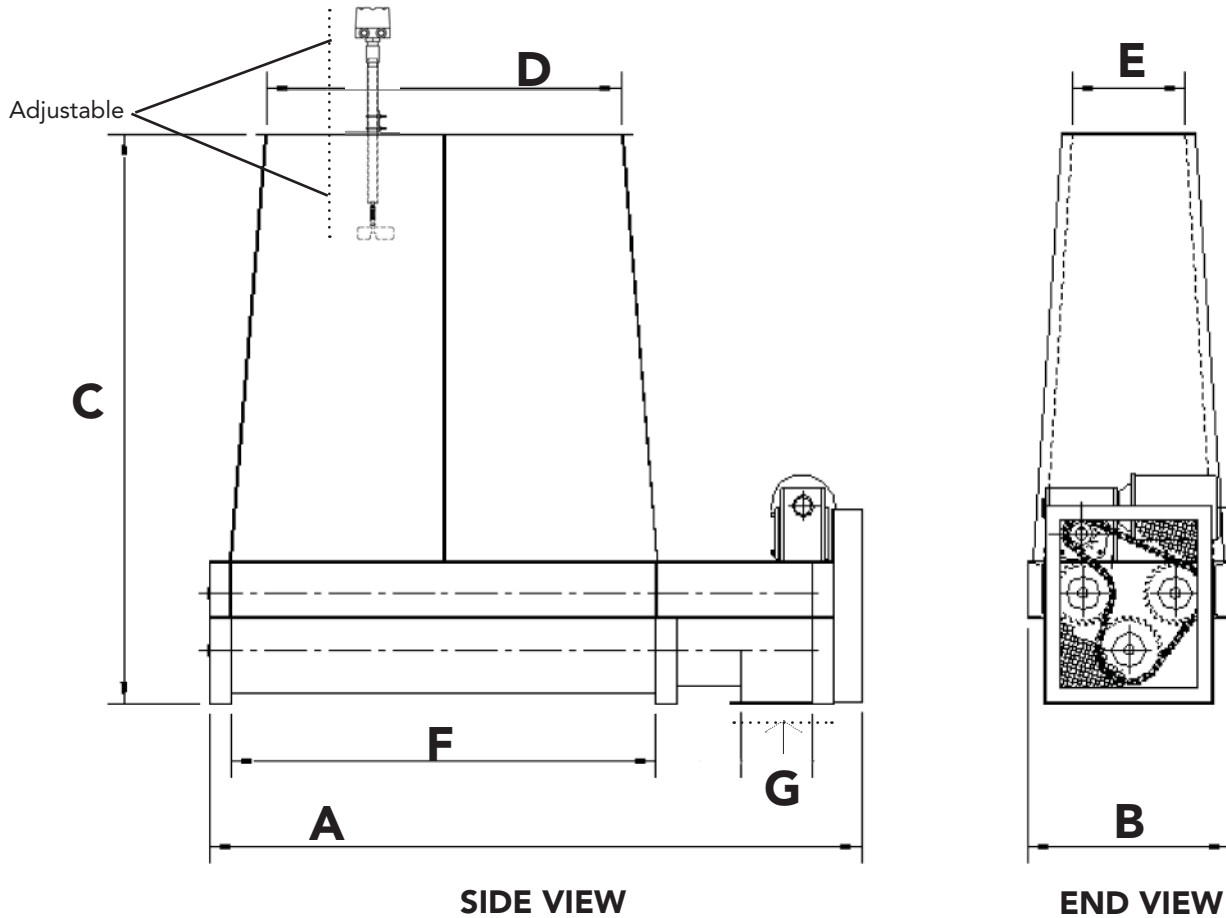

Dimensions

1 Ton (0.9 MT) Case Ice Dispenser

A.	7'-8"	(2337 mm)
B.	28 9/16"	(736 mm)
C.	6'-8"	(2032 mm)
D.	4'-2"	(1270 mm)
E.	1'-4"	(406 mm)
F.	5'-0"	(1524 mm)
G.	0'-10"	(254 mm)

Notes:

1. For 480v / 3ph / 60 Hz or 380v / 3 ph / 50 Hz
2. Starter motor for Case Ice Dispenser can be incorporated into the main rake control panel (additional charge).
3. NSF or USDA approved plastic hopper optional.

Weights and Capacities

Case Ice Dispenser	Weight - (Empty)	Capacity	Drive Motor	Delivery Rate
CID-1000	900 lbs (408 kg)	1 US Ton (0.9 MT)	5 HP (3.7 kW)	7 US TPH (6.3 MTPH)

North Star Ice Equipment Corp.

8151 Occidental Avenue South
 P.O. Box 80227
 Seattle, WA 98108 USA
 Tel: 206-763-7300

Toll-free in USA: 1-800-321-1381
 Fax: 206-763-7323
 Email: info@northstarice.com

North Star

© 2011 North Star Ice Equipment Corporation.
 Printed in USA 5.11.1.

www.northstarice.com